

# OPERATING INSTRUCTIONS

## 2m 5/8 Wave Three-Element High Performance FRP Shell Gain Vertical Antenna F-23A

**DIAMOND**  
ANTENNA

www.radcom.es

### Description

- Three piece joint FRP element structure employing newly developed direct joint system enables the antenna to;
  - Achieve enough strength to compete with one piece structure element by overlapping upper and lower FRP element directly.
  - Obtain perfect waterproof structure at the element joint section by using ring gasket.
  - Assemble or disassemble if necessary by simply fastening or loosening of few connection points.
- Unstable vswr caused by weather conditions is eliminated by perfect waterproof structure. In addition, anti-corrosion and rust free structure of the antenna enables it to be used at seaside or contaminated industrial areas without any precautions.
- DC ground structure of the antenna protects the radio equipment from high voltage caused by thunder lightning.
- Element length and the parameter of the phase inductor are determined by our years of experience and experiments to have maximum high performance.
- C-LOAD structure employed at the upper element improves the propagation efficiency of the antenna better than conventional two-element vertical antenna.

### Assembly

To begin with, put middle element out about 10cm (3.9") from middle element FRP shell and put upper element out about 10cm (3.9") from upper element FRP shell.

- Connect middle element and lower element by securing set screws firmly.

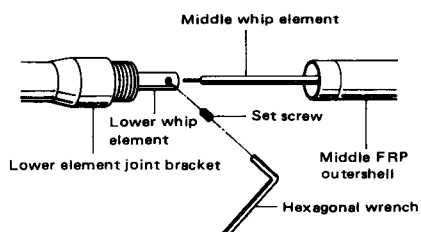

- Put middle element shell into lower element shell until it reaches the gasket and

fix them with joint element shell joint brackets.

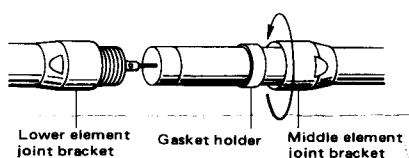

- Connect upper element and middle element by securing set screws firmly.

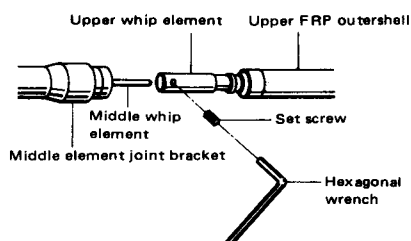

- Put upper FRP element shell into lower FRP element shell until it reaches the gasket and fasten them with joint bracket.

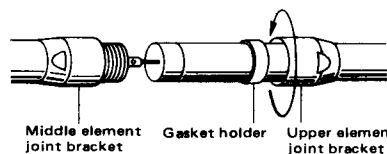

- Fasten each connecting section firmly to have no gap between each shell with wrench.

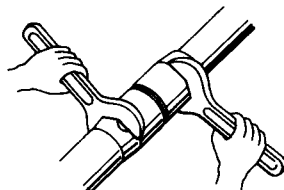

- Attach three radial elements as shown in Fig. A.

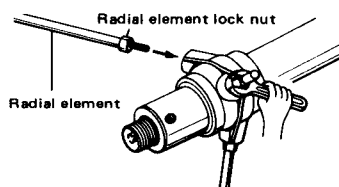

- Attach mast brackets to support pipe by securing set screws. Connect a coaxial cable to the feedpoint section through support pipe. Then, attach support pipe to the bottom of the antenna with set screw by aligning the holes at the bottom of the feedpoint section and the upper part of support pipe.

- Attach the antenna to mast as shown in Fig. A by taking the entire balance in account.

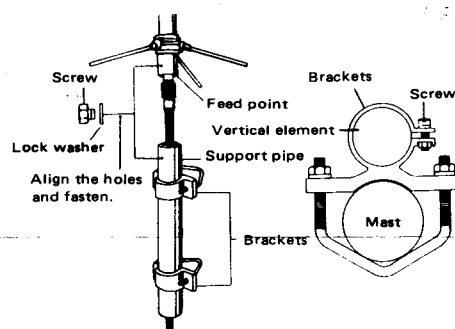
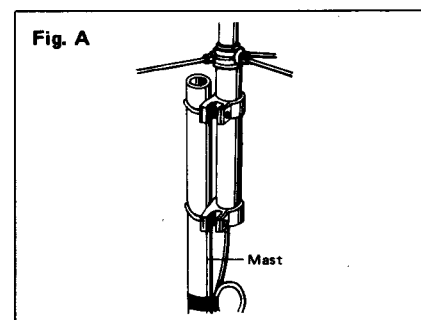

### Adjustment

The F-23A is completely adjustment free. If vswr of the antenna is extremely high, it is most likely due to the trouble in contact point somewhere. Be sure to see if those contact points are firmly fastened or correctly soldered. And coaxial cable connected to the antenna has to be those of 50ohm impedance.

Note: Though the F-23A employs DC ground structure, circuit across the center conductor and ground section is open circuited if it is measured by volt-ohm meter. If it is close circuited, be sure to see coaxial cable and connector section carefully.

## VSWR

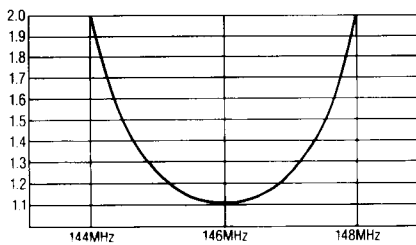

## Part name (number)

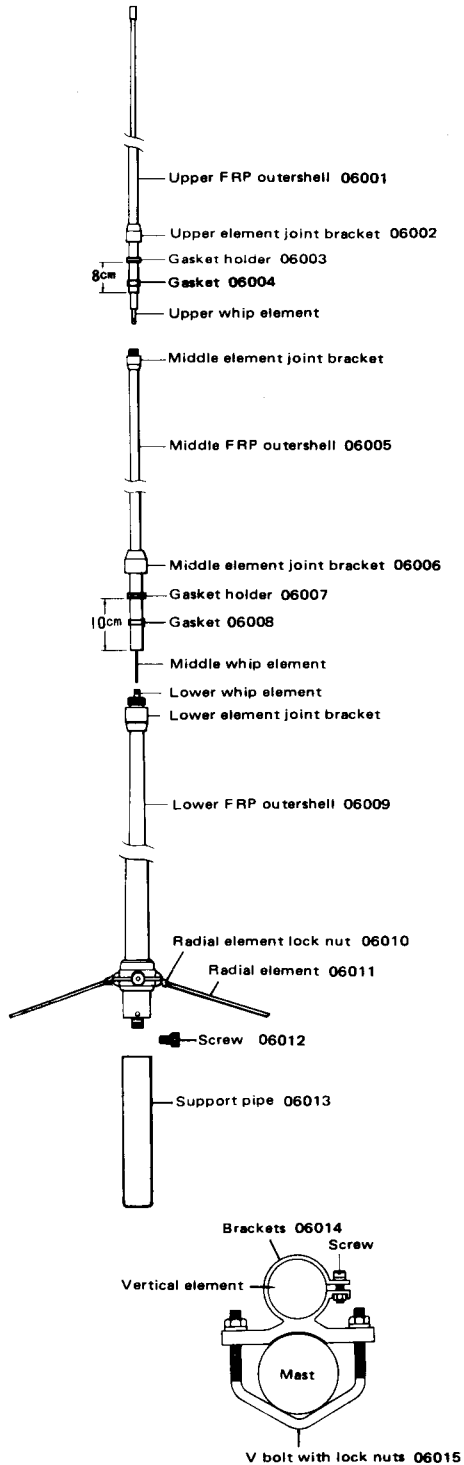

## Specifications:

Frequency	144-148MHz
Gain	7.8dB
Impedance	50ohms
VSWR	Less than 1.5:1
Max. input power	200W
Max. wind resistance	40m/sec (112.5MPH)
Mast diameter accepted	30-62mm (1-1/5" to 2-2/5")
Length	4.53m (178.3")
Weight	1.6kg (3.5lbs.)
Connector	UHF female
Type	5/8 wave three-element

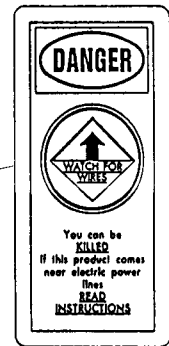

## FOR YOUR SAFETY

Read the following safety precautions before start assembling the antenna.

- Assemble the antenna on the ground or wide and flat place such as on balcony before installation.
- Do not assemble or install the antenna on a place where you can not have enough distance from any electric power lines.
- Do not install the antenna on a rainy or windy day.
- Do not attempt to install the antenna only by yourself. Installing the antenna alone on the roof may lead you dangerous accident. Always ask your friends for help installing the antenna.
- Do not use iron or aluminum ladder at a reachable distance from any electric power lines.
- Do not install the antenna on a mast which is not grounded properly.
- Do not have your family members or friends touch or come close to the antenna, unless they have realized its potential danger.

## TO AVOID FATAL ACCIDENT

- Do not attempt to sustain the antenna, or any part of support structure if it begins to fall down. Let it fall by itself.
- Do not attempt to remove or restore the antenna or any part of support structure if it touches a electric power line by chance. Let it be as it is, do not touch it, and call your local electric power company immediately.

## IN CASE OF AN ACCIDENT

- Do not touch a person or an animal who is or seems to be in contact with the antenna or any support structure which is fallen on a live electric power line. Touching one may lead you to be electrocuted.
- Do not attempt to separate a person or an animal who is or seems to be in contact with the antenna or any support structure which is fallen on a live electric power line by yourself. Call or have someone call a police officer, ambulance, doctor immediately.

## ANTENNA INSTALLATION PRECAUTIONS

To determine antenna installation location, there are several factors to be taken into account. First thing is antenna propagation direction to specific target stations. As to whether there is any obstacles such as tall buildings on the line of sight. Next is specific installation location. As to whether specific location is adequate in terms of antenna support and surrounding safety.

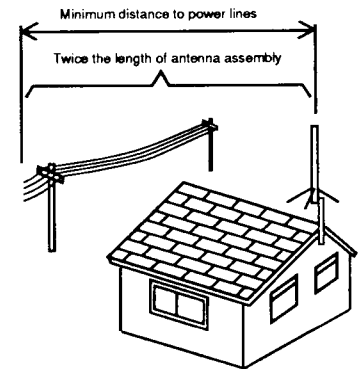

- Do not attempt to install the antenna by yourself if you do not have any experience in installing base station antenna. Ask your experienced friends or professional for help.
- Do not attempt to install the antenna at a location where does not have enough distance from nearby electric power lines. It is advised to install the antenna at least twice of total antenna height from nearby electric power lines.
- Do not install the antenna on any type of tower, pole or telescopic mast which exceeds 30 feet high, if you do not have enough experience in installing the antenna on that kind of location. Ask your experienced friends or professional for help.
- Do not use more than 1/10' section if you install the antenna on iron plumber's pipe. Attach guy wire if multiple pipes are used to install the antenna.

# DIAMOND ANTENNA CORPORATION

15-1, 1-chome, Sugamo Toshimaku, Tokyo 170, Japan Phone: (03) 3947-1411 Telex: 272 2420 DIATNA J Cable Address: DIANTNA