

Product Specifications

L6TNM-PS

Type N Male Positive Stop™ for 1-1/4 in LDF6-50 cable



CHARACTERISTICS

General Specifications

Interface	N Male
Body Style	Straight
Brand	HELIAX® OnePiece™
Mounting Angle	Straight

Electrical Specifications

Connector Impedance	50 ohm
Operating Frequency Band	0 – 3300 MHz
Cable Impedance	50 ohm
3rd Order IMD	-116 dBm @ 910 MHz
3rd Order IMD Test Method	Two +43 dBm Carriers
RF Operating Voltage, maximum (vrms)	707.00 V
dc Test Voltage	2000 V
Outer Contact Resistance, maximum	0.30 mOhm
Inner Contact Resistance, maximum	2.00 mOhm
Insulation Resistance, minimum	5000 MOhm
Average Power	0.6 kW @ 900 MHz
Peak Power, maximum	10.00 kW
Insertion Loss, typical	0.05 dB
Shielding Effectiveness	-130 dB

Product Specifications

L6TNM-PS

Outline Drawing

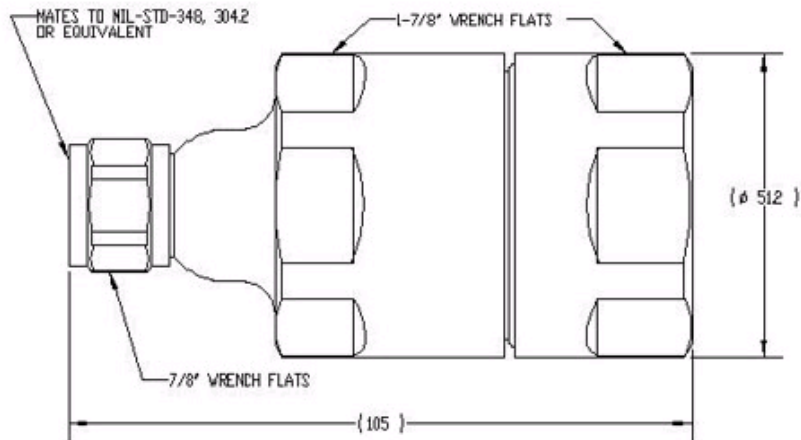

Mechanical Specifications

Outer Contact Attachment Method	Ring-flare
Inner Contact Attachment Method	Captivated
Outer Contact Plating	Trimetal
Inner Contact Plating	Silver
Attachment Durability	25 cycles
Interface Durability	500 cycles
Interface Durability Method	IEC 169-16:9.5
Connector Retention Tensile Force	1779 N 400 lbf
Connector Retention Torque	10.85 N-m 96.00 in lb
Insertion Force	66.72 N 15.00 lbf
Insertion Force Method	MIL-C-39012C-3.12, 4.6.9
Pressurizable	No
Coupling Nut Proof Torque	4.52 N-m 40.00 in lb
Coupling Nut Retention Force	444.82 N 100.00 lbf
Coupling Nut Retention Force Method	MIL-C-39012C-3.25, 4.6.22

Dimensions

Nominal Size	1-1/4 in
Diameter	51.31 mm 2.02 in
Length	104.90 mm 4.13 in
Weight	608.35 g 1.34 lb

Product Specifications

L6TNM-PS



Environmental Specifications

Operating Temperature	-55 °C to +85 °C (-67 °F to +185 °F)
Storage Temperature	-55 °C to +85 °C (-67 °F to +185 °F)
Immersion Depth	1 m
Immersion Test Mating	Unmated
Immersion Test Method	IEC 60529:2001, IP68
Water Jetting Test Mating	Unmated
Water Jetting Test Method	IEC 60529:2001, IP66
Moisture Resistance Test Method	MIL-STD-202F, Method 106F
Mechanical Shock Test Method	MIL-STD-202F, Method 213B, Test Condition C
Thermal Shock Test Method	MIL-STD-202F, Method 107G, Test Condition A-1, Low Temperature -55 °C
Vibration Test Method	MIL-STD-202F, Method 204D, Test Condition B
Corrosion Test Method	MIL-STD-1344A, Method 1001.1, Test Condition A

Standard Conditions

Attenuation, Ambient Temperature	20 °C 68 °F
Average Power, Ambient Temperature	40 °C 104 °F

Return Loss

Frequency Band	VSWR	Return Loss (dB)
45–400 MHz	1.02	39.00
401–805 MHz	1.02	39.00
806–960 MHz	1.02	39.00
961–1709 MHz	1.03	37.00
1710–2170 MHz	1.03	36.00
2170–2399 MHz	1.04	35.00
2400–2700 MHz	1.04	34.00
2700–3500 MHz	1.05	32.00
3400–3600 MHz	1.07	30.00

Regulatory Compliance/Certifications

Agency	Classification
RoHS 2002/95/EC	Compliant by Exemption
China RoHS SJ/T 11364-2006	Above Maximum Concentration Value (MCV)



* Footnotes

www.commscope.com/andrew

Join the Evolution

©2010 CommScope, Inc. All rights reserved.

All trademarks identified by ® or ™ are registered trademarks or trademarks, respectively, of CommScope. All specifications are subject to change. See www.commscope.com/andrew for the most current information.

page 3 of 4
3/10/2010

Product Specifications

L6TNM-PS

Immersion Depth Immersion at specified depth for 24 hours
Insertion Loss, typical $0.05\sqrt{\text{freq}}$ (GHz) (not applicable for elliptical waveguide)

