

Product Specifications



L4PDR-C

7-16 DIN Male Right Angle for 1/2 in LDF4-50A cable



CHARACTERISTICS

General Specifications

Interface	7-16 DIN Male
Body Style	Right angle
Brand	HELIAX®
Mounting Angle	Right angle

Electrical Specifications

Connector Impedance	50 ohm
Operating Frequency Band	0 – 4000 MHz
3rd Order IMD Test Method	Two +43 dBm Carriers
Average Power	1.1 kW @ 900 MHz
Cable Impedance	50 ohm
dc Test Voltage	4000 V
Inner Contact Resistance	0.80 mOhm
Insertion Loss, typical	0.05 dB
Insulation Resistance, minimum	5000 MOhm
Outer Contact Resistance	1.50 mOhm
Peak Power, maximum	40.00 kW
RF Operating Voltage, maximum (vrms)	1415.00 V
Shielding Effectiveness	-110 dB
3rd Order IMD	-120 dBm @ 910 MHz

Product Specifications

L4PDR-C



Outline Drawing

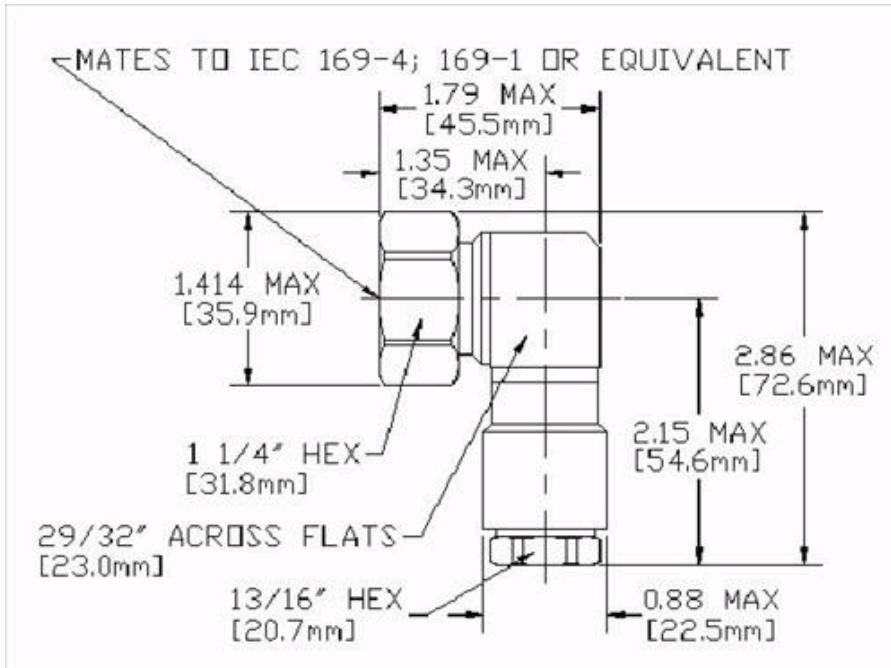

Mechanical Specifications

Outer Contact Attachment Method	Self-flare
Attachment Durability	25 cycles
Connector Retention Tensile Force	890 N 200 lbf
Connector Retention Torque	5 N-m 48 in lb
Coupling Nut Proof Torque	25.00 N-m 221.27 in lb
Coupling Nut Retention Force	1000.00 N 224.81 lbf
Coupling Nut Retention Force Method	MIL-C-39012C-3.25, 4.6.22
Inner Contact Attachment Method	Captivated
Inner Contact Plating	Silver
Insertion Force	200.17 N 45.00 lbf
Insertion Force Method	IEC 169-1:15.2.4
Interface Durability	50 cycles
Interface Durability Method	IEC 169-4:9.5
Outer Contact Plating	Trimetal
Pressurizable	No

Dimensions

Nominal Size	1/2 in
Diameter, maximum	35.99 mm 1.42 in
Length	75.01 mm 2.95 in
Right Angle Length	71.12 mm 2.80 in
Weight	205.00 g 0.45 lb
Width	49.00 mm 1.93 in

Product Specifications

L4PDR-C



Environmental Specifications

Corrosion Test Method	MIL-STD-1344A, Method 1001.1, Test Condition A
Immersion Depth	1 m
Immersion Test Mating	Mated
Immersion Test Method	IEC 60529:2001, IP68
Mechanical Shock Test Method	MIL-STD-202, Method 213, Test Condition I
Moisture Resistance Test Method	MIL-STD-202F, Method 106F
Operating Temperature	-55 °C to +85 °C (-67 °F to +185 °F)
Storage Temperature	-55 °C to +85 °C (-67 °F to +185 °F)
Thermal Shock Test Method	MIL-STD-202F, Method 107G, Test Condition A-1, Low Temperature -55 °C
Vibration Test Method	MIL-STD-202F, Method 204D, Test Condition B
Water Jetting Test Mating	Mated
Water Jetting Test Method	IEC 60529:2001, IP66

Standard Conditions

Attenuation, Ambient Temperature	20 °C 68 °F
Average Power, Ambient Temperature	40 °C 104 °F

Return Loss

Frequency Band	VSWR	Return Loss (dB)
0–1000 MHz	1.02	39.00
1000–2500 MHz	1.07	30.00
2500–2800 MHz	1.11	26.00
2800–4000 MHz	1.33	17.00

Regulatory Compliance/Certifications

Agency	Classification
RoHS 2002/95/EC	Compliant by Exemption
China RoHS SJ/T 11364-2006	Above Maximum Concentration Value (MCV)



* Footnotes

Immersion Depth	Immersion at specified depth for 24 hours
Insertion Loss, typical	$0.05\sqrt{\text{freq (GHz)}}$ (not applicable for elliptical waveguide)