

Product Specifications



F4PNF-C

Type N Female for 1/2 in FSJ4-50B cable



CHARACTERISTICS

General Specifications

Interface	N Female
Body Style	Straight
Brand	HELIAX®
Mounting Angle	Straight

Electrical Specifications

Connector Impedance	50 ohm
Operating Frequency Band	0 – 12000 MHz
3rd Order IMD Test Method	Two +43 dBm Carriers
Average Power	0.6 kW @ 900 MHz
Cable Impedance	50 ohm
dc Test Voltage	2000 V
Inner Contact Resistance	2.00 mOhm
Insertion Loss, typical	0.05 dB
Insulation Resistance, minimum	5000 MOhm
Outer Contact Resistance	0.30 mOhm
Peak Power, maximum	10.00 kW
RF Operating Voltage, maximum (vrms)	707.00 V
Shielding Effectiveness	-110 dB
3rd Order IMD	-120 dBm @ 910 MHz

Product Specifications

F4PNFC



Outline Drawing

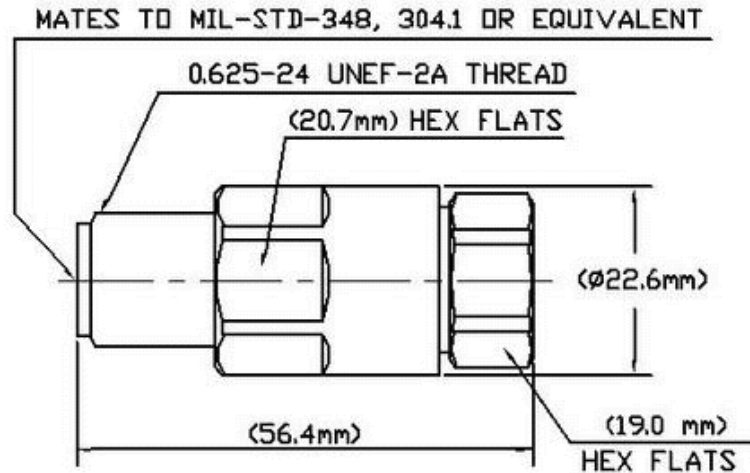

Mechanical Specifications

Outer Contact Attachment Method	Self-flare
Attachment Durability	25 cycles
Connector Retention Tensile Force	890 N 200 lbf
Connector Retention Torque	5 N-m 48 in lb
Inner Contact Attachment Method	Captivated
Inner Contact Plating	Gold
Insertion Force	66.72 N 15.00 lbf
Insertion Force Method	MIL-C-39012C-3.12, 4.6.9
Interface Durability	500 cycles
Interface Durability Method	IEC 169-16:9.5
Outer Contact Plating	Trimetal
Pressurizable	No

Dimensions

Nominal Size	1/2 in
Diameter, maximum	22.00 mm 0.87 in
Length	53.01 mm 2.09 in
Weight	95.26 g 0.21 lb

Environmental Specifications

Corrosion Test Method	MIL-STD-1344A, Method 1001.1, Test Condition A
Immersion Depth	1 m
Immersion Test Mating	Mated
Immersion Test Method	IEC 60529:2001, IP68
Mechanical Shock Test Method	MIL-STD-202F, Method 213B, Test Condition C
Moisture Resistance Test Method	MIL-STD-202F, Method 106F

Product Specifications

F4PNF-C



Operating Temperature	-55 °C to +85 °C (-67 °F to +185 °F)
Storage Temperature	-55 °C to +85 °C (-67 °F to +185 °F)
Thermal Shock Test Method	MIL-STD-202, Method 107, Test Condition A-1, Low Temperature -55 °C
Vibration Test Method	MIL-STD-202F, Method 204D, Test Condition B
Water Jetting Test Mating	Mated
Water Jetting Test Method	IEC 60529:2001, IP66

Standard Conditions

Attenuation, Ambient Temperature	20 °C 68 °F
Average Power, Ambient Temperature	40 °C 104 °F

Return Loss

Frequency Band	VSWR	Return Loss (dB)
0–1000 MHz	1.03	36.00
1000–2300 MHz	1.05	32.00
2300–3000 MHz	1.07	29.00
3000–4000 MHz	1.17	22.00
4000–8000 MHz	1.38	16.00
8000–10200 MHz	1.5	14.00

Regulatory Compliance/Certifications

Agency

RoHS 2002/95/EC
China RoHS SJ/T 11364-2006

Classification

Compliant by Exemption
Above Maximum Concentration Value (MCV)



* Footnotes

Immersion Depth	Immersion at specified depth for 24 hours
Insertion Loss, typical	$0.05\sqrt{\text{freq (GHz)}}$ (not applicable for elliptical waveguide)