

Product Specifications



AL5NM-PS

Type N Male Positive Stop™ for 7/8 in AL5-50 and AVA5-50 cable



CHARACTERISTICS

General Specifications

Interface	N Male
Body Style	Straight
Mounting Angle	Straight

Electrical Specifications

Connector Impedance	50 ohm
Operating Frequency Band	0 – 5200 MHz
3rd Order IMD Test Method	Two +43 dBm Carriers
Average Power	0.6 kW @ 900 MHz
Cable Impedance	50 ohm
dc Test Voltage	2000 V
Inner Contact Resistance	2.00 mOhm
Insertion Loss, typical	0.05 dB
Insulation Resistance, minimum	5000 MOhm
Outer Contact Resistance	0.30 mOhm
Peak Power, maximum	10.00 kW
RF Operating Voltage, maximum (vrms)	707.00 V
Shielding Effectiveness	-130 dB
3rd Order IMD	-116 dBm @ 910 MHz

Outline Drawing

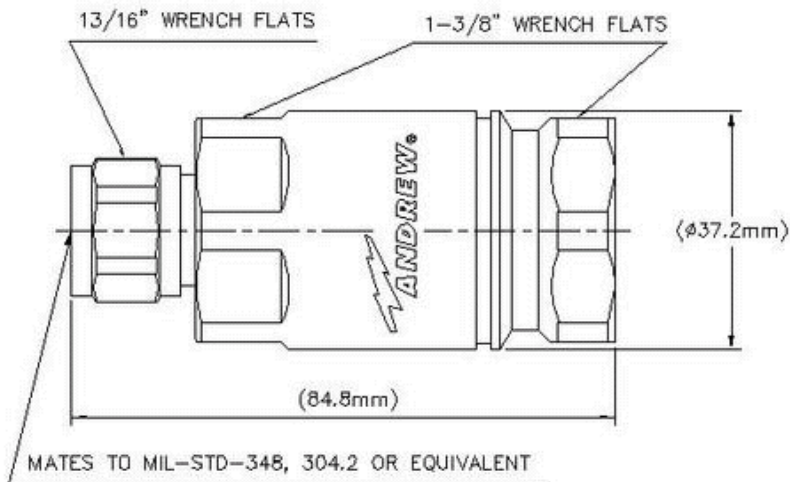

Mechanical Specifications

Outer Contact Attachment Method	Ring-flare
Attachment Durability	25 cycles
Connector Retention Tensile Force	300 lbf 1334 N
Connector Retention Torque	72 in lb 8 N·m
Coupling Nut Proof Torque	40.00 in lb 4.52 N·m
Coupling Nut Retention Force	100.00 lbf 444.82 N
Coupling Nut Retention Force Method	MIL-C-39012C-3.25, 4.6.22
Inner Contact Attachment Method	Captivated
Inner Contact Plating	Silver
Insertion Force	15.00 lbf 66.72 N
Insertion Force Method	MIL-C-39012C-3.12, 4.6.9
Interface Durability	500 cycles
Interface Durability Method	IEC 169-16:9.5
Outer Contact Plating	Trimetal
Pressurizable	No

Dimensions

Nominal Size	7/8 in
Diameter, maximum	1.47 in 37.21 mm
Length	3.39 in 86.11 mm
Weight	236.00 g 0.52 lb

Environmental Specifications

Corrosion Test Method	MIL-STD-1344A, Method 1001.1, Test Condition A
Immersion Depth	1 m

Product Specifications



Immersion Test Mating	Unmated
Immersion Test Method	IEC 60529:2001, IP68
Mechanical Shock Test Method	MIL-STD-202F, Method 213B, Test Condition C
Moisture Resistance Test Method	MIL-STD-202F, Method 106F
Operating Temperature	-55 °C to +85 °C (-67 °F to +185 °F)
Storage Temperature	-55 °C to +85 °C (-67 °F to +185 °F)
Thermal Shock Test Method	MIL-STD-202F, Method 107G, Test Condition A-1, Low Temperature -55 °C
Vibration Test Method	IEC 60068-2-6
Water Jetting Test Mating	Unmated
Water Jetting Test Method	IEC 60529:2001, IP66

Standard Conditions

Attenuation, Ambient Temperature	20 °C 68 °F
Average Power, Ambient Temperature	40 °C 104 °F

Return Loss

Frequency Band	VSWR	Return Loss (dB)
50–1000 MHz	1.02	39.00
1010–2200 MHz	1.03	38.00
2210–3000 MHz	1.04	35.00
3010–4000 MHz	1.07	29.00
4010–5200 MHz	1.13	24.00

* Footnotes

Immersion Depth	Immersion at specified depth for 24 hours
Insertion Loss, typical	$0.05 \sqrt{\text{freq (GHz)}}$ (not applicable for Elliptical Waveguide)